



OVERVIEW OF GEZE DOOR CLOSER SYSTEMS  
OVERHEAD AND INTEGRATED DOOR CLOSERS,  
AND FLOOR SPRINGS



# GEZE INNOVATIVE DOOR CLOSER SYSTEMS

## TABLE OF CONTENTS

<b>GEZE door closer systems</b>	<b>4</b>
<hr/>	
<b>GEZE overhead door closers with guide rail</b>	
Brief description of the variants	<b>5</b>
Overview table for GEZE system TS 5000	<b>8</b>
<hr/>	
<b>GEZE overhead door closers with link arm</b>	
Brief description of the variants	<b>10</b>
Overview table for GEZE system TS 4000 / TS 2000	<b>12</b>
<hr/>	
General product information about GEZE overhead door closers	<b>14</b>
<hr/>	
<b>GEZE integrated door closers - Boxer series</b>	
Brief description of the variants	<b>15</b>
Overview table for the GEZE Boxer series	<b>17</b>
<hr/>	
<b>GEZE floor springs</b>	
Brief description of the variants	<b>18</b>
Overview table for GEZE floor springs	<b>20</b>
<hr/>	
<b>Reference photos</b>	
GEZE Overhead door closers with guide rail	<b>22</b>
GEZE Overhead door closers with link arm	<b>24</b>
GEZE Integrated door closers - Boxer series	<b>26</b>
GEZE Floor springs	<b>28</b>
<hr/>	
<b>GEZE House: Possible areas of application for GEZE products</b>	<b>30</b>

# GEZE INNOVATIVE DOOR CLOSER SYSTEMS

## GEZE door closer systems – Versatile and reliable

### Innumerable optical and technical options

As one of the world's leading suppliers of door technology systems, GEZE offers innovative solutions for door closer systems. GEZE products have always been developed around the needs of customers, therefore the company offers direct solutions for individual requirements – aesthetic, functional and economical.

Door closers from GEZE impress with their intelligent functionality, their high performance, and their long life spans, as well as the integrated design lines. GEZE's quality management system has been certified to ISO 9001. GEZE door closers have been inspected and certified in accordance with the applicable standards EN 1154, EN 1155 and EN 1158. Production of these products is regularly monitored by independent test institutes. All these measures guarantee the high quality of GEZE products.

At GEZE, comprehensive customer support and advice have top priority. From draft planning through execution to maintenance of the systems. First-class spare parts management supplements the range of services.

### The new GEZE door closer TS 5000 Ecline: High access convenience and large closing force

With the new TS 5000 Ecline system, GEZE is taking a further step forward in the development of its door closers, and is bringing a completely optimised, innovative door closer to the market. It fulfills both fire protection and barrier-free building requirements. Doors with leaf widths of up to 1250 millimetres (EN5) can be opened easily with reduced force. In the case of emergency, the TS 5000 Ecline closes doors safely and reliably.

Visit [www.geze.com/ecline](http://www.geze.com/ecline) for more detailed information about the new TS 5000 Ecline.

### Overview of GEZE door closers

Overhead door closers with guide rail



TS 5000 Ecline

Overhead door closers with link arm



TS 4000

Integrated door closers



Boxer 2-4

Floor springs

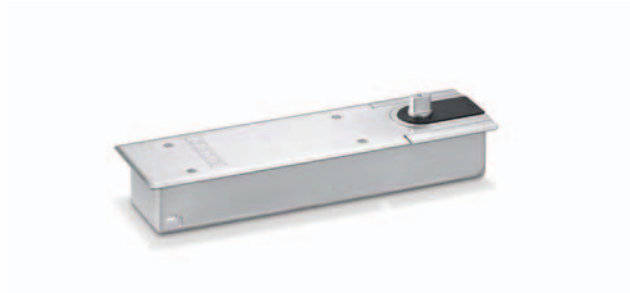

TS 550 NV

More detailed information about the GEZE door closers can be found in the respective door closer product brochures.

# GEZE OVERHEAD DOOR CLOSERS WITH GUIDE RAIL

## GEZE Overhead door closers with guide rail

### Brief description of the variants

#### For single-leaf doors

Door closers for single-leaf doors with guide rails represent modern closing technology on every door. The wide range of GEZE door closer technologies ensures that there is a technical solution for every requirement, for example with electric hold-open device, with smoke switch control unit or with a free swing function. These products meet the DIBt guidelines for hold-open devices as well as the norms and standards, such as DIN EN 1154 and 1155, and also have a CE mark or a general building approval (DiBt).



#### **TS 1500 G: Door closer with guide rail**

The overhead door closer TS 1500 G with guide rail for single-leaf doors is particularly suitable for internal doors with door leaf widths of up to 850 mm and can be used for right and left single-action doors without conversion.



#### **TS 3000 V: Door closer up to 1100 mm leaf width**

The overhead door closer TS 3000 V is suitable for right and left single-leaf doors of up to 1100 mm and for installation on fire and smoke protection doors.



#### **TS 5000 Ecline / TS 5000 L Ecline: Door closer with high access convenience and large closing force**

These overhead door closers are suitable for barrier-free, easy opening single-leaf doors of up to 1250 mm leaf width (closing force EN5). They are the ideal system solution for barrier-free building and guarantee high access convenience thanks to the opening support integrated in the guide rail.



#### **TS 5000 / TS 5000 L: Door closer up to 1400 mm leaf width**

These overhead door closers for single-leaf doors represent clear lines. They are approved for use on fire and smoke-proof doors. Special version: GEZE door closer TS 5000 S with delayed closing action adjustable from the front.

## GEZE OVERHEAD DOOR CLOSERS WITH GUIDE RAIL

---



### **TS 5000 E / TS 5000 L-E: Door closer with electric hold-open device**

The electric hold-open device in the guide rail allows these overhead door closers to be adjusted continuously to an exact hold-open angle. When combined with an external smoke switch control unit (e.g. RSZ 6), the hold-open function is released in the event of a fire and the door closes safely.



### **TS 5000 EFS 3-6: Door closer with free swing function**

The overhead door closer TS 5000 EFS for single-leaf doors is fitted with the free swing function. This enables people to go through the door by applying reduced physical force in the opening or closing direction once the door has been opened. When combined with an external smoke switch control unit, the electric free swing function is released and the door closes automatically in the event of a fire.



### **TS 5000 RFS 3-6: Door closer with free swing function and smoke switch control unit**

The overhead door closer TS 5000 RFS for single-leaf doors is fitted with an integrated smoke switch and the electric free swing function. This enables people to go through the door by applying reduced physical force in the opening or closing direction, e.g. in homes for the elderly or hospitals, after the door has been opened once, e.g. in the morning. The electric free swing function is released by the integrated smoke switch control unit and the door closes automatically in the event of a fire.



### **TS 5000 R / TS 5000 L-R: Door closer with smoke switch control unit**

These overhead door closers with electric hold-open device and integrated smoke switch control unit are approved for installation on single-leaf fire and smoke protection doors. In the event of a fire, the smoke detector triggers and the door closes automatically.

# GEZE OVERHEAD DOOR CLOSERS WITH GUIDE RAIL

## For double-leaf doors

The integrated closing sequence control (ISM) ensures the correct closing sequence of both leaves on double-leaf doors. When the door is closed, the active leaf remains in waiting position until the passive leaf is closed and releases the active leaf via the closing sequence control. The double-leaf door closer systems of the ISM series offer numerous specific setting options. Various versions, example with electric hold-open device, with smoke switch control unit or free swing function fulfil almost every requirement.

These products meet the DIBt guidelines for hold-open devices as well as the norms and standards, such as DIN EN 1154, 1155 and 1158, and also have a CE mark or a general building approval (DIBt).

### TS 5000 ISM / TS 5000 L-ISM / TS 5000 L-ISM VPK: Door closer with closing sequence control



System solutions comprising two TS 5000 with adjustable closing force 2-6 in accordance with EN 1154, combined with the ISM guide rail, tested in accordance with EN 1158 and approved for fire and smoke protection doors.

For opposite hinge side standard or panic function on the active leaf only: TS 5000 L-ISM

For opposite hinge side full panic requirements up to X dimension 125 mm: TS 5000 L-ISM VPK

### TS 5000 E-ISM / TS 5000 L-E-ISM / TS 5000 L-E-ISM VPK: Door closer with electric hold-open device



These overhead door closers for double-leaf doors with integrated, invisible closing sequence control are equipped with an electric hold-open function in the guide rail which allows continuous setting of the hold-open angle. When the system is combined with an external smoke switch control unit, the hold-open position is released in the event of a fire. These door closers are approved for use on fire and smoke protection doors.

### TS 5000 R-ISM / TS 5000 L-R-ISM / TS 5000 L-R-ISM VP: Door closer with hold-open device and smoke switch control unit



This system solution for double-leaf doors with electric hold-open device on both sides and integrated smoke switch control unit is approved for use on fire and smoke protection doors. In the event of a fire, the smoke detector triggers and the door closes automatically. For opposite hinge side: TS 5000 L-R-ISM (standard or panic function on the active leaf only) and TS 5000 L-R-ISM VP (full panic requirements up to X dimension 100 mm).

### TS 5000 R-ISM/0: Door closer with free swing function and smoke switch control unit



In the case of the system solution TS 5000 R-ISM/0 for double-leaf doors, the free swing function is realised using the R-ISM/0 guide rail and the TS 5000 EHY 3-6 door closer on the active leaf. The door must be opened once to approximately 90°. The passive leaf closes automatically thanks to the TS 5000 overhead door closer. In the event of a fire, the electric free swing function is released by the integrated smoke switch control unit and the door closes safely. Additionally, hold-open magnets can be fitted to the active and / or passive leaf in order to hold the respective leaf open.

# GEZE OVERHEAD DOOR CLOSERS WITH GUIDE RAIL

## Overview table for GEZE System TS 5000

For single-leaf doors

	TS 1500 G	TS 3000 V	TS 5000 ECLine	TS 5000 L ECLine	TS 5000	TS 5000 L	TS 5000 E	TS 5000 L-E	TS 5000 R	TS 5000 L-R	TS 5000 EFS 3-6	TS 5000 RFS 3-6
Approval for fire and smoke protection doors <sup>13)</sup>		•	•	•	•	•	•	•	•	•	•	•
Barrier-free in accordance with DIN 18040 up to leaf width (max.) in mm	EN1 750	EN4 1100	EN5 1250	EN5 1250	EN4 1100	EN4 1100	FSA	FSA	FSA	FSA	FSA FL	FSA FL
Closing force in accordance with EN 1154	1	1-4	3-5	3-5	2-6	2-6	2-6	2-6	2-6	2-6	3-6	3-6
Door leaf width (max.) in mm	750	1100	1250	1250	1400	1400	1400	1400	1400	1400	1400	1400
<b>Installation options</b>												
Door leaf installation, hinge side	•	•	•		•		•		•		•	•
Transom installation, hinge side <sup>9)</sup>		•		•		•					• <sup>4)</sup>	• <sup>4)</sup>
Opening angle (max.) hinge side <sup>8)</sup>	180°	180°	180°	180°	180°	180°	180°	8)	180°	8)	180°	180°
Door leaf installation, opposite hinge side		•		•		•		•		•		
Transom installation, opposite hinge side <sup>9)</sup>		•	•		•							
<b>Functions</b>												
Adjustable closing force		•	•	•	•	•	•	•	•	•	•	•
Adjustable back check		• <sup>2)</sup>	• <sup>12)</sup>	•	• <sup>12)</sup>	•	•	•	•	•		
Adjustable hydraulic latching action	•	•	•	•	•	•	•	•	•	•	•	•
Adjustable delayed closing action					• <sup>1)</sup>							
Adjustable closing speed	•	•	•	•	•	•	•	•	•	•	•	•
Integrated opening support			•	•								
Opening support can be switched off			•	•								
Flexible opening restrictor		•			•	•	•	•	•	•		•
Mechanical hold-open device <sup>3)</sup>	•	•	•	•	•	•						
Electric hold-open device							•	•	•	•		
Electrical hold-open device for free swing or hold-open magnet											•	•
Integrated smoke switch control unit									•	•		•
Integrated mechanical closing sequence control												

• = yes

o = optional

\* = up to EN4 / 1100 mm with standard closer and up to EN5 / 1250 mm with ECLine closer

<sup>1)</sup> Model TS 5000 S with delayed closing action

<sup>2)</sup> Model TS 3000 V BC

<sup>3)</sup> Can be retrofitted, not on F and RD doors

<sup>4)</sup> Special model

<sup>5)</sup> System solution consisting of 2 overhead door closers TS 5000 (L) and suitable ISM, E-ISM or R-ISM guide rail for installation on hinge side or opposite hinge side (version BG)

<sup>6)</sup> Free swing function on active leaf, system solution consisting of 1 overhead door closer TS 5000 E-HY on the active leaf and 1 overhead door closer TS 5000 on the passive leaf

<sup>7)</sup> Maximum door leaf width of the active leaf



## GEZE OVERHEAD DOOR CLOSERS WITH GUIDE RAIL

## For double-leaf doors

	TS 5000 ISM <sup>5)</sup>	TS 5000 L-ISM <sup>5)</sup>	TS 5000 L-ISM VPK <sup>5)</sup>	TS 5000 E-ISM <sup>5)</sup>	TS 5000 L-E-ISM <sup>5)</sup>	TS 5000 L-E-ISM VPK <sup>5)</sup>	TS 5000 R-ISM <sup>5)</sup>	TS 5000 L-R-ISM <sup>5)</sup>	TS 5000 L-R-ISM VP <sup>5)</sup>
Approval for fire and smoke protection doors	●	●	●	●	●	●	●	●	●
Barrier-free in accordance with DIN 18040 up to leaf width (max.) in mm	EN4/1100 EN5/1250*	EN4/1100 EN5/1250*	EN4 1100	FSA (FSA FL)	FSA	FSA	FSA (FSA FL)	FSA	FSA
Closing force in accordance with EN 1154	2-6	2-6	2-6	2-6	2-6	2-6	2-6	2-6	2-6
Door leaf width (max.) in mm	1400	1400	1400	1400	1400	1400	1400	1400	1400
<b>Installation options</b>									
Door leaf installation, hinge side	●			●			●		
Transom installation, hinge side <sup>9)</sup>									
Opening angle (max.) hinge side <sup>8)</sup>	180°	<sup>8)</sup>	<sup>8)</sup>	180°	<sup>8)</sup>	<sup>8)</sup>	180°	<sup>8)</sup>	<sup>8)</sup>
Door leaf installation, opposite hinge side		●	●		●	●		●	●
Transom installation, opposite hinge side <sup>9)</sup>									
<b>Functions</b>									
Adjustable closing force	●	●	●	●	●	●	●	●	●
Adjustable back check	●	●	●	●	●	●	●	●	●
Adjustable hydraulic latching action	●	●	●	●	●	●	●	●	●
Adjustable delayed closing action									
Adjustable closing speed	●	●	●	●	●	●	●	●	●
Integrated opening support									
Opening support can be switched off									
Flexible opening restrictor	●	●	●	●	●	●	●	●	● <sup>11)</sup>
Mechanical hold-open device <sup>3)</sup>	●	●	●						
Electric hold-open device				●	●	●	●	●	●
Electrical hold-open device for free swing or hold-open magnet	○			○			○		
Integrated smoke switch control unit							●	●	●
Integrated mechanical closing sequence control	●	●	●	●	●	●	●	●	●

<sup>8)</sup> Opening angle (max.) opposite hinge side, see chapter: General product functions and information

<sup>9)</sup> For fire protection doors with corresponding proof of suitability

<sup>11)</sup> Only for restricted use

<sup>12)</sup> Back check in transom installation opposite hinge side not effective

<sup>13)</sup> Valid for Germany. Specifications for other countries can be different and need to be checked with the local requirements. Please contact your local GEZE subsidiary/representative.

FSA = Hold-open system

FSA FL = Hold-open system free swing

## GEZE OVERHEAD DOOR CLOSERS WITH LINK ARM

### GEZE overhead door closers with link arm

#### Brief description of the variants

#### For single-leaf doors

From the smallest overhead door closer to numerous variations for use with fire and smoke protection doors: The door closer range with link arm offers versatile combination options. These have a closing force with variable adjustment and are suitable for right and left single-action doors without conversion being necessary.



#### **TS 1000 C: Door closer with adjustable closing speed up to 950 mm leaf width**

With the overhead door closer TS 1000 C, the closing speed and latching action can be adjusted. The variable closing force in two sizes is set by simply turning the bearing block for the link arm around.



#### **TS 1500: Door closer with adjustable closing speed up to 1100 mm leaf width**

With the overhead door closer TS 1500, the closing speed and latching action can be adjusted. The variable closing force in two sizes is set by simply turning the bearing block for the link arm around. It is optionally available with a mounting plate and is suitable for both right and left single-action doors without conversion.



#### **TS 2000 NV: Door closer with variable closing force up to 1100 mm leaf width**

With the overhead door closer TS 2000 NV with closing force with variable adjustment in accordance with DIN EN 1154 in sizes 2-4, the closing speed can conveniently be set from the front. The latching action is adjusted from the front using a valve.



#### **TS 2000 V: Door closer with variable closing force up to 1250 mm leaf width**

With the TS 2000 V overhead door closer with variable closing force in accordance with DIN EN 1154 in sizes 2/4/5, the closing speed can conveniently be set from the front. The latching action is adjusted using the link arm.



#### **TS 4000: Door closer with back check**

With the overhead door closer TS 4000, the closing force is set from the front. The back check and the thermo-stabilised closing speed with large visual closing force display can also be set from the front.



#### **TS 4000 E: Door closer with electric hold-open device**

This overhead door closer TS 4000 E with electric hold-open device is authorised for installation on fire and smoke protection doors in combination with an external smoke switch control unit. In the event of fire or a power failure, the hold-open function is released and the door closes safely. The closing force and the thermo-stabilised closing speed with large visual closing force display can easily be set from the front.

# GEZE OVERHEAD DOOR CLOSERS WITH LINK ARM



## TS 4000 R: Door closer with an integrated smoke switch

This overhead door closer with electric hold-open device and a smoke switch control unit integrated in the closer housing has been approved for installation on fire and smoke protection doors. In the event of a fire, the smoke detector triggers and the door closes automatically. When used on double-leaf doors, the TS 4000 R must be installed on the active leaf.



## TS 4000 EFS: Door closer with hold-open device and free swing arm

The TS 4000 EFS overhead door closer is fitted with the free swing function. This enables people to go through the door by applying reduced physical force in the opening or closing direction once the door has been opened. When combined with an external smoke switch control unit the electric free swing function is released and the door closes automatically and safely in the event of a fire.



## TS 4000 RFS: Door closer with free swing arm and smoke switch control unit

The TS 4000 RFS overhead door closer is equipped with an integrated smoke switch control unit and free swing function. This enables people to go through the door by applying reduced physical force in the opening or closing direction – e.g. in homes for the elderly or hospitals – after the door has been opened once, e.g. in the morning. The electric free swing function is released by the integrated smoke switch control unit and closes the door automatically and safely in the event of a fire.



## TS 4000 Tandem: Door closer for very large and heavy doors

The TS 4000 Tandem is a combination comprising the TS 4000 EN 5-7 and the TS 4000 EN 1-6 door closers. The door closers are mounted on an adapter plate with joint axis. Suitable for leaf widths > 1600 mm with closing force > EN7.

## For double-leaf doors

The double-leaf door closer systems of the IS series with integrated hydraulic closing sequence control are approved for installation on fire and smoke protection doors. The integrated closing sequence control with protection against intentional damage ensures the correct closing sequence of both door leaves for double-leaf doors. When the door is closed, the active leaf remains in waiting position until the passive leaf is closed and releases the active leaf via the closing sequence control. The closing force according to EN 1154 with visual closing force display and closing speed can be set from the front. The latching action is adjusted using the link arm.



## TS 4000 IS: Door closer with integrated closing sequence control

The TS 4000 IS overhead door closer system with integrated hydraulic closing sequence control has been approved for installation on fire and smoke protection doors. Closing force in accordance with EN 1154 size 1-6 with visual closing force display and closing speed are set from the front.



## TS 4000 E-IS: Door closer with integrated closing sequence control and electric hold-open device

The TS 4000 E-IS overhead door closer system with integrated hydraulic closing sequence control and electric hold-open device has been approved for installation on fire and smoke protection doors. The electric hold-open device can be variably adjusted from 80° to 175° in accordance with EN 1155. The closing force in accordance with EN 1154 size 1-6 with visual closing force display and closing speed can be adjusted from the front.



## TS 4000 R-IS: Door closer with closing sequence control, hold-open device and smoke switch control unit

The TS 4000 R-IS overhead door closer system with electric hold-open device and integrated smoke switch control unit has been approved for installation on fire and smoke protection doors. In the event of a fire, the smoke detector triggers and the door closes automatically. The electric hold-open device can be variably adjusted from 80° to 175° in accordance with EN 1155. The closing force in accordance with EN 1154 size 1-6 with visual closing force display and closing speed can be adjusted from the front.

# GEZE OVERHEAD DOOR CLOSERS WITH LINK ARM

## Overview table for GEZE system TS 2000 / TS 4000

### For single-leaf doors

	TS 1000 C	TS 1500	TS 2000 NV	TS 2000 V	TS 4000 size 1-6	TS 4000 size 5-7	TS 4000 E	TS 4000 R	TS 4000 EFS	TS 4000 RFS	TS 4000 Tandem
Approval for fire and smoke protection doors <sup>8)</sup>			•		•	•	•	•	•	•	•
Barrier-free in accordance with DIN 18040 up to leaf width (max.) in mm	EN3 950	EN4 1100	EN4 1100	EN4 1100	EN4 1100		FSA	FSA	FSA FL	FSA FL	
Closing force in accordance with EN 1154	2/3	3/4	2-4	2/4/5	1-6	5-7	1-6	1-6	1-6	1-6	> 7
Door leaf width (max.) in mm	950	1100	1100	1250	1400	1600	1400	1400	1400	1400	>1600
<b>Application possibilities</b>											
Door leaf installation, hinge side	•	•	•	•	•	•	•		•		•
Opening angle (max.) hinge side <sup>7)</sup>	180°	180°	180°	180°	180°	180°	180°	180°	180°	180°	180°
Door leaf installation, opposite hinge side			• <sup>6)</sup>	• <sup>6)</sup>	• <sup>6)</sup>	• <sup>6)</sup>					• <sup>6)</sup>
Transom installation, opposite hinge side	•	•	•	•	•	•	•	•	•	•	•
<b>Functions</b>											
Adjustable closing force	•	•	•	•	•	•	•	•	•	•	•
Adjustable back check			• <sup>2)</sup>	• <sup>2)</sup>	•	•					•
Adjustable hydraulic latching action	•	•	•	•	•	•	•	•	•	•	•
Adjustable delayed closing action					• <sup>1)</sup>						
Adjustable closing speed	•	•	•	•	•	•	•	•	•	•	•
Mechanical hold-open device <sup>3)</sup>	•	•	•	•	•	• <sup>4)</sup>					
Electric hold-open device							•	•			
Electric hold-open device for free swing									•	•	
Integrated smoke switch control unit								•		•	
Integrated closing sequence control											

• = yes

<sup>1)</sup> Model TS 4000 S with delayed closing action

<sup>2)</sup> Model TS 2000 NV BC/TS 2000 V BC

<sup>3)</sup> Not for F and RD doors

<sup>4)</sup> Hold-open linkage only effective up to EN6

<sup>5)</sup> System solution comprising a TS 4000 IS/ E-IS/ R-IS on the active leaf in combination with a TS 4000/E/R-IS second unit on the passive leaf and release mechanism in the frame

<sup>6)</sup> In parallel arm installation

<sup>7)</sup> Opening angle (max.) opposite hinge side, see chapter: Further information for overhead door closers

<sup>8)</sup> Valid for Germany. Specifications for other countries can be different and will therefore have to be compared to the local requirements. Please contact your local GEZE subsidiary/representative.

FSA = Hold-open system

FSA FL = Hold-open system free swing

# GEZE OVERHEAD DOOR CLOSERS WITH LINK ARM

## For double-leaf doors

	TS 4000 IS <sup>5)</sup>	TS 4000 E-IS <sup>5)</sup>	TS 4000 R-IS <sup>5)</sup>
Approval for fire and smoke protection doors <sup>8)</sup>	•	•	•
Barrier-free in accordance with DIN 18040 up to leaf width (max.) in mm	EN4 1100	FSA	FSA
Closing force in accordance with EN 1154	1-6	1-6	1-6
Door leaf width (max.) in mm	1400	1400	1400
<b>Application possibilities</b>			
Door leaf installation, hinge side	•	•	
Opening angle (max.) hinge side <sup>7)</sup>	180°	180°	- <sup>7)</sup>
Door leaf installation, opposite hinge side			
Transom installation, opposite hinge side	•	•	•
<b>Functions</b>			
Adjustable closing force	•	•	•
Adjustable back check			
Hydraulic latching action	•	•	•
Adjustable delayed closing action			
Adjustable closing speed	•	•	•
Mechanical hold-open device <sup>3)</sup>	•		
Electric hold-open device		•	•
Electric hold-open device for free swing			
Integrated smoke switch control unit			•
Integrated closing sequence control	•	•	•

# GEZE OVERHEAD DOOR CLOSERS

## General product information about GEZE overhead door closers

### Door closer sizes

acc. to EN 1154	Door leaf width in mm
Size 1	up to 750
Size 2	from 750 to 850
Size 3	from 850 to 950
Size 4	from 950 to 1100
Size 5	from 1100 to 1250
Size 6	from 1250 to 1400
Size 7	from 1400 to 1600

### Notes for door closers with guide rail for installation on the opposite hinge side

Note: The max. door opening angle must be limited by a door stopper or by use of the GEZE T-Stop guide rail!

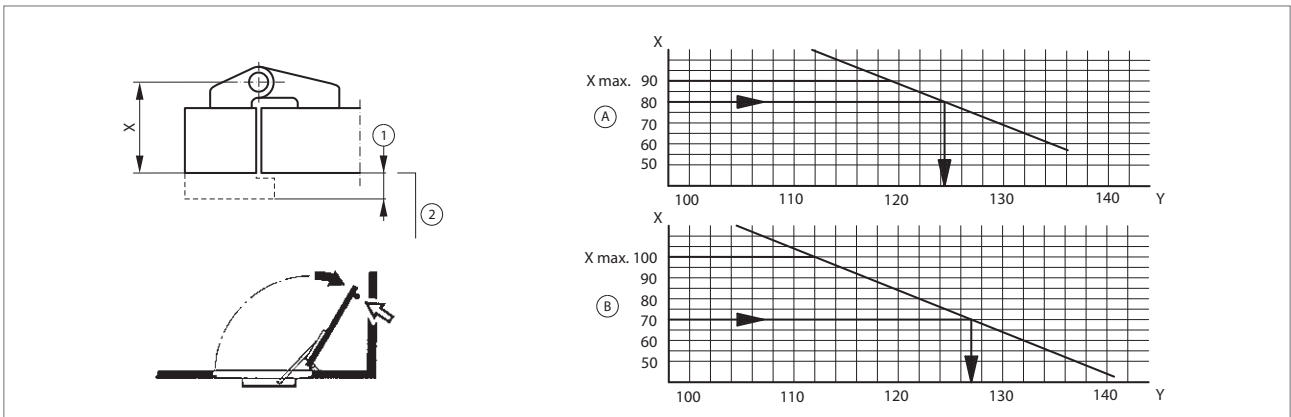

- 1 = Overlap max. 15 mm
- 2 = Flush-mounted door
- X = Distance pivot point to contact area of guide rail  
X dimension max. = 100 mm (double-leaf), 90 mm (single-leaf)
- A = Single-leaf systems
- B = Double-leaf systems
- Y = Door opening angle

Special mounting dimensions are used when the X dimension is wider – on request.

### Notes for door closers with link arm for installation on the opposite hinge side

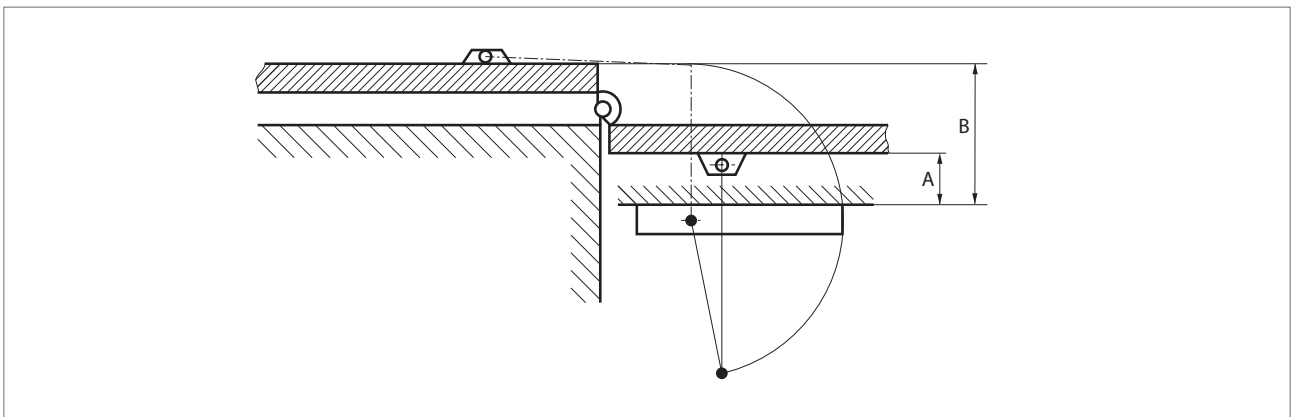

- A = Reveal depth
- B = Reveal depth + 2 door thickness + 2 pivot point distance

Door opening up to 180° is only possible if the following dimensions are not exceeded:  
A = 70 mm and B = 200 mm

## GEZE integrated door closers - Boxer series

### Brief description of the variants

#### For single-leaf doors

The integrated Boxer door closer is installed completely in the door leaf and frame. The guide rail can only be seen when the door is open. The closing force in accordance with DIN EN 1154, the closing speed, the hydraulic latching action and the hydraulic back check can be adjusted conveniently from above when installed. For fire protection doors an additional suitability certificate is required with the door. The door opening angle must be limited to approx. 120°.



#### **Boxer: Integrated door closer for 1-leaf doors**

The integrated Boxer door closer for single-leaf doors in the versions EN 2-4 and EN 3-6 can be used for left and right single-action doors without conversion. The variant EN 2-4 2V additionally has an independent valve control for regulating the latching action speed. Thus, the door speed cannot only be increased, but the door can also be stopped within an opening angle of 10° and less.



#### **Boxer E: Integrated door closer with electric hold-open device**

The integrated door closer Boxer with electric hold-open device in the guide rail is suitable for single-leaf doors. The E guide rail with electric hold-open device has been tested in accordance with EN 1155. The retention force of the hold-open device has variable adjustment, the hold-open position can be set to between approx. 80° and 120°. The hold-open position can be overridden, i.e. the door can be opened wider if necessary.



#### **Boxer EFS 4-6: Integrated door closer with electric free swing function**

The integrated door closer Boxer EFS 4-6 allows barrier-free passage of single-leaf doors thanks to its free swing function. This enables people to go through the door by applying reduced physical force in the opening or closing direction – e.g. in homes for the elderly or hospitals – after the door has been opened once, e.g. in the morning. The door closer can be used for right and left single-action doors without conversion.



#### **Boxer P: Integrated door closer for double-action doors**

The integrated door closer Boxer 2-4 with double-action guide rail is suitable for use on lightweight double-action doors with low access frequency.

## GEZE INTEGRATED DOOR CLOSERS

### For double-leaf doors

The Boxer ISM system is designed for double-leaf doors and has an integrated mechanical closing sequence control, which ensures that the active leaf always closes after the passive leaf. When closing the active leaf whilst both leaves are open, it remains in waiting position until the passive leaf is closed and releases the active leaf via the closing sequence control. The system can be used for active leaf types DIN left or right without conversion. In addition, the closing sequence control of the ISM rail is extremely resistant to vandalism, i.e. the system is not damaged even if the active leaf is pushed intentionally to close out of the waiting position. The ISM guide rail is only visible when opening the door.



#### **Boxer ISM: Door closer with integrated closing sequence control**

The system GEZE Boxer ISM for double-leaf doors is made up of the Boxer 2-4 or Boxer 3-6 in the door leaves and the ISM guide rail with integrated mechanical closing sequence control in accordance with EN 1158 in the door frame.



#### **Boxer E-ISM: Door closer with electric hold-open device**

The system GEZE Boxer E-ISM for double-leaf doors is made up of the Boxer 2-4 or Boxer 3-6 in the door leaves and the E-ISM guide rail in the door frame. The guide rail is fitted with an integrated closing sequence control in accordance with EN 1158 and an electric hold-open device on both sides in accordance with EN 1155. The retention force of the hold-open devices and an electric, the hold-open position can be adjusted to between approx. 80° and 120°. The hold-open position can be overridden, i.e. the door can be opened wider if necessary.



#### **Boxer ISM-EFS: Integrated door closer with free swing function**

The system GEZE Boxer ISM-EFS for double-leaf doors is made up of the Boxer EFS 4-6 with free swing function on the active leaf, a Boxer 3-6 or 2-4 on the passive leaf and the ISM guide rail with integrated closing sequence control in accordance with EN 1158 in the door frame. The free swing function enables people to go through the active leaf by applying reduced physical force in the opening or closing direction – e.g. in homes for the elderly or hospitals – after the door has been opened once, e.g. in the morning.



# GEZE INTEGRATED DOOR CLOSERS

## Overview table for the GEZE Boxer range

	For single-leaf doors						For double-leaf doors		
	Boxer Gr. 2-4 / 2-4 2V	Boxer Gr. 3-6	Boxer E Gr. 2-4	Boxer E Gr. 3-6	Boxer EFS 4-6	Boxer P	Boxer ISM	Boxer E-ISM	Boxer ISM-EFS
Approval for smoke and fire protection doors <sup>1)</sup>	•	•	•	•	•	•	•	•	•
Barrier-free in accordance with DIN 18040 up to leaf width (max.) in mm	EN4 1100	EN4 1100	FSA	FSA	FSA FL	EN4 1100	EN4 1100	FSA	FSA FL
Closing force acc. to EN 1154	2-4	3-6	2-4	3-6	4-6	2-4	2-4/ 3-6	2-4/ 3-6	4-6/ 3-6 (2-4)
Door leaf width (max.) in mm	1100	1400	1100	1400	1400	1100	1100/ 1400	1100/ 1400	1400/ 1400 (1100)
Leaf weight (max.) in kg	130	180	130	180	180	80	130/180	130/180	180/130
<b>Application possibilities</b>									
Closer body integrated in the door leaf	•	•	•	•	•	•	•	•	•
Guide rail integrated in the door frame	•	•	•	•	•	•	•	•	•
Opening angle (max.)	120°	120°	120°	120°	120°	120°	120°	120°	120°
<b>Functions</b>									
Closing force, adjustable	•	•	•	•	•	•	•	•	•
Back check, adjustable	•	•	•	•	•	•	•	•	•
Latching action, adjustable	•	•	•	•	•	•	•	•	•
Closing speed, adjustable	•	•	•	•	•	•	•	•	•
Mechanical hold-open device <sup>2)</sup>	•	•				•	•		
Electric hold-open device			•	•				•	
Electric hold-open device for free swing					•				•
Mechanical closing sequence control, integrated							•	•	•
Flexible opening restrictor			•	•	•		•	•	•

• = yes

<sup>1)</sup> For smoke and fire protection doors an additional suitability certificate is required for the door.

<sup>2)</sup> Can be retrofitted, not to smoke and fire protection doors

FSA = Hold-open system (in conjunction with RSZ 6)

FSA FL = Hold-open system free swing

# GEZE FLOOR SPRINGS

## GEZE floor springs

### Brief description of the variants

#### For single-leaf doors

GEZE floor springs can be used to close single and double-action doors made of different materials in a reliable manner whilst remaining optically noteless. The product range includes systems for light and heavy leaf weights as well as door closers for use on fire and smoke protection doors.

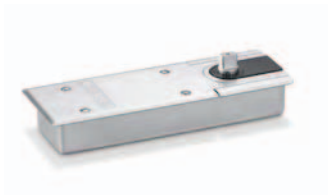

#### **TS 500 NV / TS 500 N EN 3: Floor springs for doors of up to 1100 mm**

The TS 500 NV and TS 500 N EN 3 versions are two floor springs for use with doors with a maximum leaf width of 1100 mm. The very low overall height of just 42 mm is a welcome benefit for both new constructions and renovation projects.



#### **TS 550 NV: Floor spring for frequently used and heavy doors**

The TS 550 NV has been specifically further developed and is used for heavy single-leaf single-action and double-action doors. Its versatility and sturdiness make the TS 550 NV ideal for use in highly frequented areas.



#### **TS 550 NV F: Floor spring for fire and smoke protection doors**

The TS 550 NV F was developed for subtle installation on heavy-duty fire and smoke protection doors. The low installation height of only 54 mm makes it easy to fit, even to existing doors. The closing speed and hydraulic latching action can be adjusted. The integrated fixed back check prevents uncontrolled opening of the door. The closing force can be infinitely variable adjusted from above. The safety valve provides protection against intentional overload.



#### **TS 550 NV E: Floor spring with electric hold-open device**

The TS 550 NV E has been tested in accordance with DIN EN 1155 and can be held open in any position between 75° and 160° due to the electric hold-open device. This allows the door to be held open for any length of time. The closing speed and hydraulic latching action can be adjusted. The closing force can be infinitely variable adjusted from above. A safety valve helps to prevent intentional overloading. The closer is authorised for use with renowned smoke detector systems by DIBt (the German Centre of Competence for Construction).



#### **TS 550 E-G / TS 550 F-G: Floor springs with lever and guide rail**

These versions with lever and guide rail can be used for doors with carrying hinges. For both versions, the non-protruding spindle in conjunction with an extremely flat lever enables an opening angle of 180° with a floor clearance of 9 mm. A safety valve helps prevent intentional overloading. The electric hold-open device in accordance with DIN EN 1155 permits the TS 550 E-G to be held in any position between 80° and 150°.

### For double-leaf doors

GEZE floor springs can be used to close single-action doors made of different materials in a reliable manner whilst remaining optical noteless. The floor springs for double-leaf doors are equipped with integrated closing sequence control according to EN 1158 or with additional electric hold-open device.



#### **TS 550 IS: Floor spring with integrated closing sequence control**

The TS 550 IS is used on double-leaf doors. A safety valve helps prevent intentional overloading. TS 550 IS is also suitable for leaves with unequal widths.



#### **TS 550 E-IS: Floor spring with electric hold-open device**

The electric hold-open device of the TS 550 E-IS allows double-leaf doors to be held open independently of one another at any angle between 80° and 175° for as long as desired. The closing speed and hydraulic latching action can be adjusted. The closing force can be infinitely variable regulated from above. A safety valve helps prevent intentional overloading. The closer is authorised for use with renowned smoke detector systems, and tested and certified by DIBt (the German Centre of Competence for Construction).



#### **TS 550 IS-G / TS 550 E-IS-G: Floor springs with lever and guide rail**

These floor spring versions with lever and guide rail can be used for double-leaf doors with carrying hinges. The non-protruding spindle in conjunction with an extremely flat lever enables an opening angle of 180° with a floor clearance of 9 mm. A safety valve helps prevent intentional overloading. The electric hold-open device in accordance with DIN EN 1155 permits the TS 550 E-IS-G to be held in any position between 80° and 150°.

# GEZE FLOOR SPRINGS

## Overview table for GEZE floor springs

### For single-leaf doors

	TS 500 NV	TS 500 N EN 3	TS 550 NV	TS 550 NV F	TS 550 NVE	TS 550 F-G	TS 550 E-G
Approval for fire and smoke protection doors <sup>1)</sup>				•	•	•	•
Barrier-free in accordance with DIN 18040 up to leaf width (max.) in mm	EN4 1100	EN3 950	EN4 1100	EN4 1100	FSA	EN4 1100	FSA
Closing force in accordance with EN 1154	1-4	3	3-6	3-6	3-6	3-6	3-6
Max. door leaf width (mm)	1100	950	1400	1400	1400	1400	1400
Leaf weight (max.) in kg	150	100	300	300	300		
<b>Application possibilities</b>							
Single-action doors (right/left)	•	•	•	•	•	•	•
Opening angle (max.)	170°	170°	170°	180°	180°	180°	180°
Double-action doors	•	•	•				
<b>Functions</b>							
Closing force, adjustable	•		•	•	•	•	•
Back check, fixed	•	•	•	•	•		
Hydraulic latching action, adjustable	•		•	•	•	•	•
Closing speed, adjustable	•	•	•	•	•	•	•
Mechanical hold-open device	•	•	•				
Electric hold-open device					•		•
Mechanical closing sequence control, integrated							
Hold-open angle	optional 85° 90° 105° 120°	optional 85° 90° 105° 120°	85° up to 165°		75° up to 160°		80° up to 150°

• = yes

<sup>1)</sup> Valid for Germany. Specifications for other countries can be different and will therefore have to be compared to the local requirements. Please contact your local GEZE subsidiary/representative.

FSA = Hold-open system (in conjunction with RSZ 6)

**For double-leaf doors**

	TS 550 IS	TS 550 E-IS	TS 550 IS-G	TS 550 E-IS-G
Approval for fire and smoke protection doors <sup>1)</sup>	•	•	•	•
Barrier-free in accordance with DIN 18040 up to leaf width (max.) in mm	EN4 1100	FSA	EN4 1100	FSA
Closing force in accordance with EN 1154	3-6	3-6	3-6	3-6
Max. door leaf width (mm)	1400	1400	1400	1400
Leaf weight (max.) in kg	250	250		
<b>Application possibilities</b>				
Single-action doors (right/left)	•	•	•	•
Opening angle (max.)	180°	180°	180°	180°
Double-action doors				
<b>Functions</b>				
Closing force, adjustable	•	•	•	•
Back check, fixed	•	•		
Hydraulic latching action, adjustable	•	•	•	•
Closing speed, adjustable	•	•	•	•
Mechanical hold-open device				
Electric hold-open device		•		•
Mechanical closing sequence control, integrated	•	•	•	•
Hold-open angle		80° up to 175°		80° up to 150°

## GEZE OVERHEAD DOOR CLOSERS WITH GUIDE RAIL

### Reference photos

#### GEZE overhead door closers with guide rail



BMW Welt, Munich, Germany (Photo: Robert Sprang)



Textile and Industry Museum, Augsburg, Germany (Photo: Dirk Wilhelmy)

## GEZE OVERHEAD DOOR CLOSERS WITH GUIDE RAIL



Vocational school, Friedrichshafen, Germany (Photo: Dirk Wilhelmy)



Augustinum retirement home, Stuttgart, Germany (Photo: Dirk Wilhelmy)

## GEZE OVERHEAD DOOR CLOSERS WITH LINK ARM

### Reference photos

#### GEZE overhead door closers with link arm



Mövenpick Hotel, Stuttgart Airport, Germany (Photo: Nikolas Grünwald)



Sports hall, Zadar, Croatia (Photo: Robert Les)



## GEZE OVERHEAD DOOR CLOSERS WITH LINK ARM



Sports Hall, Zadar, Croatia (Photo: Robert Les)



Sparkasse, Ulm, Germany (Photo: Nikolas Grünwald)

## GEZE INTEGRATED DOOR CLOSERS

### Reference photos

#### GEZE integrated door closers - Boxer series



Court building in Gent, Belgium (Photo: Erwin Kamphuis)



Kreissparkasse, Ludwigsburg, Germany (Photo: Lazaros Filoglou)

## GEZE INTEGRATED DOOR CLOSERS



Vitra Haus, Weil am Rhein, Germany (Photo: Oliver Look)



Andels Hotel, Berlin, Germany (Photo: Stefan Dauth)

# GEZE FLOOR SPRINGS

## Reference photos

### GEZE floor springs



Vector company building, Stuttgart, Germany (Photo: Dirk Wilhelmy)



GEZE GmbH, Leonberg, Germany (Photo: Nikolaus Grünwald)



Augustinum, Stuttgart, Germany (Photo: Dirk Wilhelmy)



Glas Trösch, Kempten, Germany (Photo: Nikolaus Grünwald)

# POSSIBLE AREAS OF APPLICATION FOR GEZE PRODUCTS

You will find more product information in the relevant brochures, see ID numbers.

<b>Door technology</b>	
<b>01</b>	Overhead door closers ID 091593, ID 091594
<b>02</b>	Hold-open systems ID 091593, ID 091594
<b>03</b>	Integrated door closers ID 091609
<b>04</b>	Floor springs and all-glass fittings ID 091607
<b>05</b>	Sliding fitting systems and linear guides ID 123605, ID 000586
<b>Automatic door systems</b>	
<b>06</b>	Swing doors ID 144785
<b>07</b>	Sliding, telescopic and folding doors ID 143639
<b>08</b>	Curved sliding doors ID 135772
<b>09</b>	Revolving doors ID 132050
<b>10</b>	Activation devices and sensors ID 142655
<b>Smoke and heat extraction and window technology</b>	
<b>11</b>	Fanlight opening systems ID 127787
<b>12</b>	Electric opening and locking systems ID 127785, ID 127789
<b>13</b>	Electrical spindle and linear drives ID 127785, ID 127789
<b>14</b>	Electric chain drives ID 127785, ID 127789
<b>15</b>	Smoke and heat extraction systems ID 127785, ID 139075
<b>Safety technology</b>	
<b>16</b>	Emergency exit systems ID 132408
<b>17</b>	Access control systems ID 132158
<b>18</b>	Panic locks ID 132848
<b>19</b>	Electric strikes ID 148666
<b>20</b>	Building management system ID 132408
<b>Glass systems</b>	
<b>21</b>	Manual sliding wall systems (MSW) ID 104377
<b>22</b>	Integrated all-glass systems (IGG) ID 104366

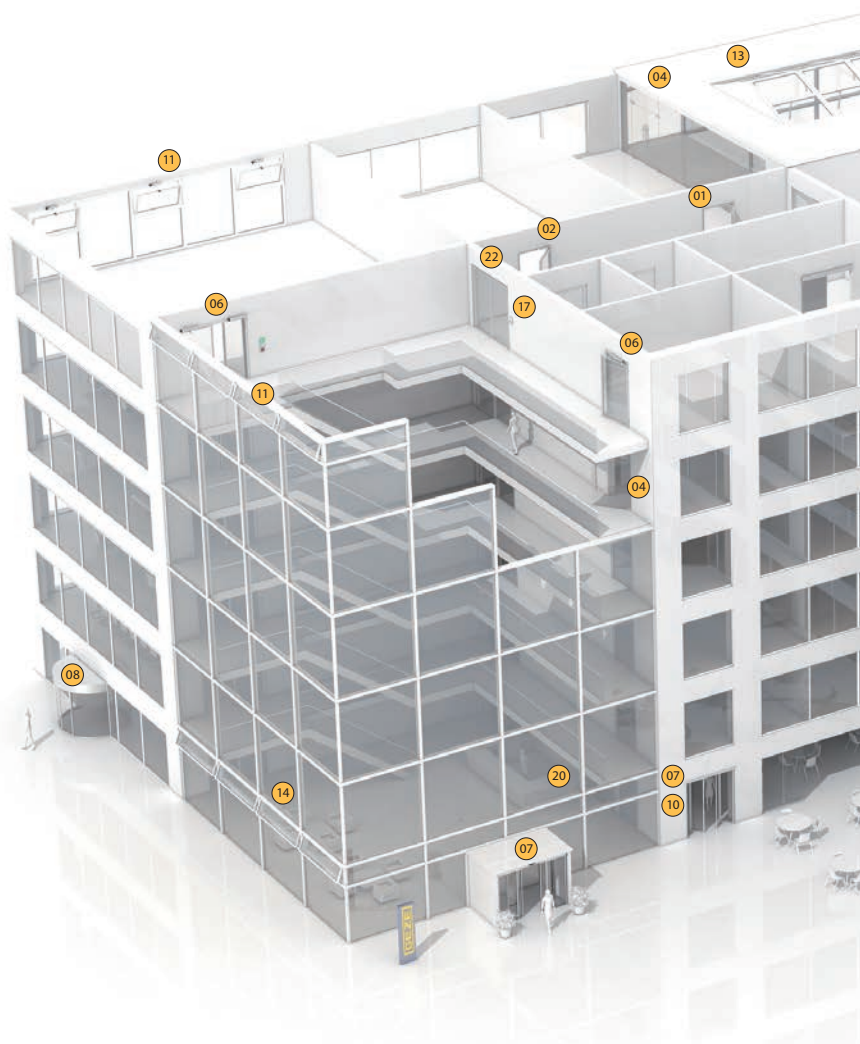

# POSSIBLE AREAS OF APPLICATION FOR GEZE PRODUCTS



---

## Door technology

---

The functionality, superior performance and reliability of GEZE door closers are impressive. A common design across the range, the ability to use them on all common door leaf widths and weights, and the fact that they can be individually adjusted makes their selection simple. They are continually being improved and enhanced with up-to-date features. For example, the requirements of fire protection and accessibility are fulfilled with a door closer system.

---

## Automatic door systems

---

GEZE automatic door systems open up a huge variety of options in door design. The latest, innovative high-performance drive technology, safety, ease of accessibility and first class universal drive design set them apart. GEZE offers complete solutions for individual requirements.

---

## Smoke and heat extraction and window technology

---

GEZE smoke and heat extraction systems and ventilation technology provide complete systems solutions combining the many requirements of different types of windows. We supply a full range from energy efficient drive systems to natural ventilation and complete solutions for supplying and extracting air, also as certified SHEVs.

---

## Safety technology

---

GEZE safety technology sets the standards where preventative fire protection, access control and anti-theft security in emergency exits are concerned. For each of these objectives GEZE offers tailored solutions, which combine the individual safety requirements in one intelligent system and close doors and windows in case of danger in a coordinated manner.

---

## Building systems

---

In GEZE's Building Management System GEZE door, window and safety products can be integrated in to the security and control systems of the building. A central control and visualisation system monitors various automation components in the building and offers security through many different networking capabilities.

---

## Glass systems

---

GEZE glass systems stand for open and transparent interior design. They can either blend discreetly into the architecture of the building or stand out as an accentuated feature. GEZE offers a wide variety of technologies for functional, reliable and aesthetic sliding wall or sliding door systems providing security with lots of design scope.

**GEZE GmbH**  
**P.O. Box 1363**  
**71226 Leonberg**  
**Germany**

**GEZE GmbH**  
**Reinhold-Vöster-Straße 21-29**  
**71229 Leonberg**  
**Germany**  
**Telefon +49 7152 203 0**  
**Telefax +49 7152 203 310**  
**www.geze.com**

**Germany**  
 GEZE GmbH  
 Niederlassung Süd-West  
 Breitwiesenstraße 8  
 71229 Leonberg  
 Tel. +49 7152 203 594  
 Fax +49 7152 203 438  
 leonberg.de@geze.com

GEZE GmbH  
 Niederlassung Süd-Ost  
 Parkring 17  
 85748 Garching bei München  
 Tel. +49 7152 203 6440  
 Fax +49 7152 203 77050  
 muenchen.de@geze.com

GEZE GmbH  
 Niederlassung Ost  
 Albert-Einstein-Ring 5  
 14532 Kleinmachnow bei Berlin  
 Tel. +49 7152 203 6840  
 Fax +49 7152 203 76849  
 berlin.de@geze.com

GEZE GmbH  
 Niederlassung Mitte/Luxemburg  
 Adenauerallee 2  
 61440 Oberursel (b. Frankfurt)  
 Tel. +49 7152 203 6888  
 Fax +49 7152 203 6891  
 frankfurt.de@geze.com

GEZE GmbH  
 Niederlassung West  
 Heltorfer Straße 12  
 40472 Düsseldorf  
 Tel. +49 7152 203 6770  
 Fax +49 7152 203 76770  
 duesseldorf.de@geze.com

GEZE GmbH  
 Niederlassung Nord  
 Haus 11, 1. OG - Theodorstr. 42-90  
 22761 Hamburg-Bahrenfeld  
 Tel. +49 7152 203 6600  
 Fax +49 7152 203 76608  
 hamburg.de@geze.com

GEZE Service GmbH  
 Niederlassung Süd-West  
 Reinhold-Vöster-Straße 25  
 71229 Leonberg  
 Tel. +49 1802 923392  
 Fax +49 7152 9233 359  
 service-leonberg.de@geze.com

GEZE Service GmbH  
 Niederlassung Süd  
 Parkring 17  
 85748 Garching bei München  
 Tel. +49 1802 923392  
 Fax +49 7152 9233 859  
 service-muenchen.de@geze.com

GEZE Service GmbH  
 Niederlassung Mitte  
 Oberurseler Str. 69  
 61440 Oberursel  
 Tel. +49 1802 923392  
 Fax +49 7152 9233 659  
 service-oberursel.de@geze.com

GEZE Service GmbH  
 Niederlassung West  
 Heltorfer Straße 12  
 40472 Düsseldorf  
 Tel. +49 1802 923392  
 Fax +49 7152 9233 559  
 service-duesseldorf.de@geze.com

GEZE Service GmbH  
 Niederlassung Ost  
 Albert-Einstein-Ring 5  
 14532 Kleinmachnow bei Berlin  
 Tel. +49 1802 923392  
 Fax +49 7152 9233 759  
 service-berlin.de@geze.com

GEZE Service GmbH  
 Niederlassung Nord  
 Theodorstr. 42-90, Haus 11  
 22761 Hamburg  
 Tel. +49 1802 923392  
 Fax +49 7152 9233 459  
 service-hamburg.de@geze.com

**Austria**  
 GEZE Austria  
 Wiener Bundesstrasse 85  
 A-5300 Hallwang  
 Tel: +43 6225 87180  
 Fax: +43 6225 87180 299  
 austria.at@geze.com

**Baltic States –  
 Lithuania / Latvia / Estonia**  
 Tel. +371 678960 35  
 baltic-states@geze.com

**Benelux**  
 GEZE Benelux B.V.  
 Industrieterrein Kapelbeemd  
 Steenoven 36  
 5626 DK Eindhoven  
 Tel. +31 4026290 80  
 Fax +31 4026290 85  
 benelux.nl@geze.com

**Bulgaria**  
 GEZE Bulgaria - Trade  
 Representative Office  
 Nickolay Haitov 34 str., fl. 1  
 1172 Sofia  
 Tel. +359 247043 73  
 Fax +359 247062 62  
 office-bulgaria@geze.com

**China**  
 GEZE Industries (Tianjin) Co., Ltd.  
 Shuangchenzhong Road  
 Beichen Economic Development  
 Area (BEDA)  
 Tianjin 300400, P.R. China  
 Tel. +86 22 26973995  
 Fax +86 22 26972702  
 chinasales@geze.com.cn

GEZE Industries (Tianjin) Co., Ltd.  
 Branch Office Shanghai  
 Jia Little Exhibition Center  
 Room C 2-102  
 Shenzhuan Rd. 6000  
 201619 Shanghai, P.R. China  
 Tel. +86 21 52340960  
 Fax +86 21 64472007  
 chinasales@geze.com.cn

GEZE Industries (Tianjin) Co., Ltd.  
 Branch Office Guangzhou  
 Room 17 C 3  
 Everbright Bank Building, No.689  
 Tian He Bei Road  
 510630 Guangzhou, P.R. China  
 Tel. +86 20 38731842  
 Fax +86 20 38731834  
 chinasales@geze.com.cn

GEZE Industries (Tianjin) Co., Ltd  
 Branch Office Beijing  
 Room 04-05, 7th Floor  
 Red Sandalwood Plaza  
 No. 27 Jianguo Road  
 Chaoyang District  
 100024 Beijing, P.R.China  
 Tel. +86 10 85756009  
 Fax +86 10 85758079  
 chinasales@geze.com.cn

**France**  
 GEZE France S.A.R.L.  
 ZAC de l'Orme Rond  
 RN 19  
 77170 Servon  
 Tel. +33 1 606260 70  
 Fax +33 1 606260 71  
 france.fr@geze.com

**Hungary**  
 GEZE Hungary Kft.  
 Hungary-2051 Biatorbágy  
 Vendel Park  
 Huber u. 1.  
 Tel. +36 23532 735  
 Fax +36 23532 738  
 office-hungary@geze.com

**Iberia**  
 GEZE Iberia S.R.L.  
 C/ Andorra 24  
 08830 Sant Boi de Llobregat  
 (Barcelona)  
 Tel. +34 902194 036  
 Fax +34 902194 035  
 info@geze.es

**India**  
 GEZE India Private Ltd.  
 MF 2 & 3, Guindy Industrial Estate  
 Ekkattuthangal  
 Chennai 600 097  
 Tamilnadu  
 Tel. +91 44 406169 00  
 Fax +91 44 406169 01  
 office-india@geze.com

**Italy**  
 GEZE Italia S.r.l  
 Sede di Vimercate  
 Via Fiorbellina 20  
 20871 Vimercate (MB)  
 Tel. +39 0399530401  
 Fax+39 039 9530459/419  
 italia.it@geze.com

Sede di Roma  
 Via Lucrezia Romana, 91  
 00178 Roma  
 Tel. +39 06 726531 1  
 Fax +39 06 726531 36  
 roma@geze.biz

**Poland**  
 GEZE Polska Sp.z o.o.  
 ul. Marywilska 24  
 03-228 Warszawa  
 Tel. +48 224 404 440  
 Fax +48 224 404 400  
 geze.pl@geze.com

**Romania**  
 GEZE Romania S.R.L.  
 IRIDE Business Park,  
 Str. Dimitrie Pompeiu nr. 9-9a,  
 Building 10, Level 2, Sector 2,  
 020335 Bucharest  
 Tel.: +40 212507 750  
 Fax: +40 316201 258  
 office-romania@geze.com

**Russia**  
 OOO GEZE RUS  
 Gamsnovskiy Per. 2  
 115191 Moscow  
 Tel. +7 495 93306 59  
 Fax +7 495 93306 74  
 office-russia@geze.com

**Scandinavia – Sweden**  
 GEZE Scandinavia AB  
 Mallslingan 10  
 Box 7060  
 18711 Täby, Sweden  
 Tel. +46 87323 400  
 Fax +46 87323 499  
 sverige.se@geze.com

**Scandinavia – Norway**  
 GEZE Scandinavia AB avd. Norge  
 Industriveien 34 B  
 2073 Dal  
 Tel. +47 63957 200  
 Fax +47 63957 173  
 norge.se@geze.com

**Scandinavia – Denmark**  
 GEZE Danmark  
 Branch office of GEZE Scandinavia AB  
 Mårkærvej 13 J-K  
 2630 Taastrup  
 Tel. +45 463233 24  
 Fax +45 463233 26  
 danmark.se@geze.com

**Singapore**  
 GEZE (Asia Pacific) Pte. Ltd.  
 21 Bukit Batok Crescent  
 #23-75 Wcega Tower  
 Singapore 658065  
 Tel: +65 6846 1338  
 Fax: +65 6846 9353  
 gezesea@geze.com.sg

**South Africa**  
 Geze South Africa (Pty) Ltd.  
 GEZE, Building 3, 1019 Morkels Close  
 Midrand 1685  
 Tel: + 87 94337 88  
 Fax: + 86 66137 52  
 info@gezesa.co.za

**Switzerland**  
 GEZE Schweiz AG  
 Zelglimatte 1A  
 6260 Reiden  
 Tel. +41 62 28554 00  
 Fax +41 62 28554 01  
 schweiz.ch@geze.com

**Turkey**  
 GEZE Kapı ve Pencere Sistemleri  
 San. ve Tic. Ltd. Sti.  
 İstanbul Anadolu Yakası Organize  
 Sanayi Bölgesi  
 Gazi Bulvarı Caddesi 8.Sokak No:8  
 Tuzla-İstanbul  
 Tel. + 90 216 45543 15  
 Fax + 90 216 45582 15  
 office-turkey@geze.com

**Ukraine**  
 LLC GEZE Ukraine  
 ul. Viskoznaya, 17,  
 Building 93-B, Office 12  
 02660 Kiev  
 Tel./Fax +38 445012225  
 office-ukraine@geze.com

**United Arab Emirates/GCC**  
 GEZE Middle East  
 P.O. Box 17903  
 Jebel Ali Free Zone  
 Dubai  
 Tel. +971 48833 112  
 Fax +971 48833 240  
 gezeme@geze.com

**United Kingdom**  
 GEZE UK Ltd.  
 Blenheim Way  
 Fradley Park  
 Lichfield  
 Staffordshire WS13 8SY  
 Tel. +44 15434430 00  
 Fax +44 15434430 01  
 info.uk@geze.com

GEZE REPRESENTATIVE